

User's Manual

CNPS12X

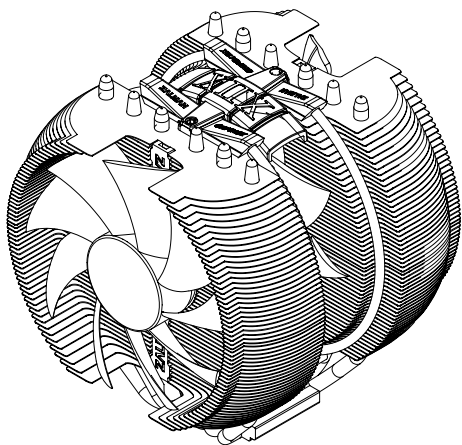

Intel Socket 2011 / 1366 / 1156 / 1155 / 775 CPUs
AMD Socket FM2 / FM1 / AM3+ / AM3 / AM2+ / AM2 CPU&APUs

To ensure safe and easy installation, please read the following precautions.

www.ZALMAN.com

Ver.121113

1. Precautions

- 1) Avoid inserting objects or hands into the fan while it is in operation to prevent product damage and injuries.
- 2) Do not ingest the Thermal Grease, and avoid its contact with skin and eyes. If contact is made with skin, wash off with water. If ingested or irritation persists, seek medical attention.
- 3) To prevent possible injuries, gloves must be worn while handling this product.
- 4) Excessive force exerted on the fan may cause damage to the fan and/or system.
- 5) Use and keep product away from reach of children.
- 6) Check the components list and condition of the product before installation. If any problem is found, contact the retailer to obtain a replacement.
- 7) During transportation of the system, the cooler must be removed. Zalman is not responsible for any damages that occur during the transport of a system.
- 8) Product design and specifications may be revised to improve quality and performance.

Disclaimer) Zalman Tech Co., Ltd. is not responsible for any damages due to external causes, including but not limited to, improper use, problems with electrical power, accident, neglect, alteration, repair, improper installation, or improper testing.

2. Specifications

Spec.		Model	CNPS12X
Material		Pure Copper and Aluminum	
Weight		1000g	
Dimensions		151(L) X 132(W) X 154(H)mm	
Dissipation Area		9,635cm ²	
Fan	Bearing		Long Life Bearing
	Quiet Mode	RPM	850 ~ 1,100rpm ±10%
		Noise Level	22dBA ± 10%
	Normal Mode	RPM	950 ~ 1,200rpm ±10%
Noise Level		24dBA ± 10%	
Thermal Grease [ZM-STG2]		Contents	3.5g
		Temperature Range	-40°C ~ +150°C (-40 ~ +302°F)

3. Components

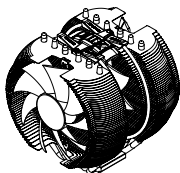

Cooler

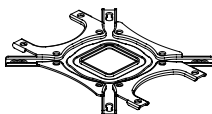

Backplate

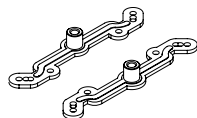

Clip Support

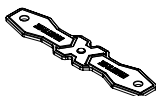

Clip



User's Manual



Wrench

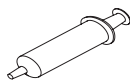

Thermal Grease
[ZM-STG2]

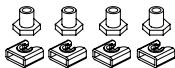

Nuts & Side Caps

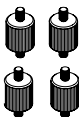

Nipple A



Nipple B



Nuts

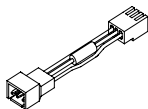

Resistor [RC5]

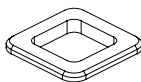

Loading Block

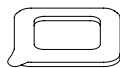

Double-sided Tape



Bolts

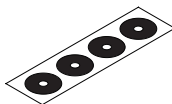

Intel Washer (Black)

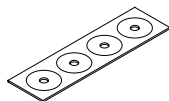

AMD Washer
(Transparent)

4. Installation Requirements

1) Space Requirements

The cooler's installation requires an unobstructed space of 151mm(width), 154mm(length), and 132mm(height), with the CPU as a central reference point. Please check if components such as ODDs and PSU protrude into the required space.

2) Air Guide Removal

Air guides on enclosures must be removed before the cooler's installation since they protrude into the cooler's required space.

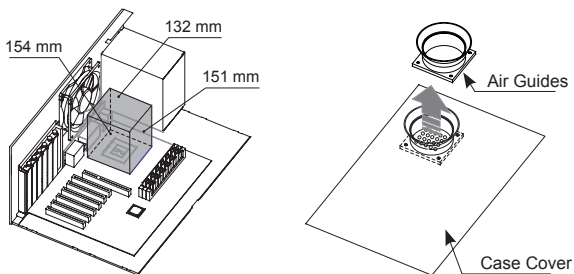

3) Cooler Orientation

As shown in the diagram below, the cooler's Reverse Fan (distinguished by Comb Shape Blades) should face the case's exhaust rear fan so that air flows from the cooler toward the case's exhaust rear fan to be released.

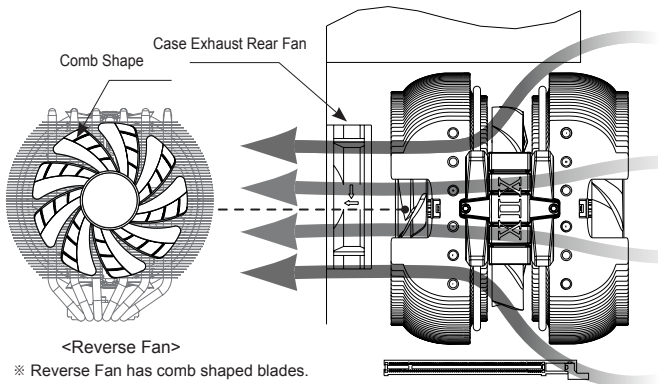

5. Installation

A. Clip support installation according to the Socket Types

※ Chose the appropriate installation method on the pages depending on a user's socket type, and then install clip support.

1) Intel Socket 2011 Installation

- Fasten Nipple B to the clip support's hole on the motherboard.
 - ※ Socket 2011 Installation does not require the Backplate, Loading Block and Washer(black) used for Intel's Socket.

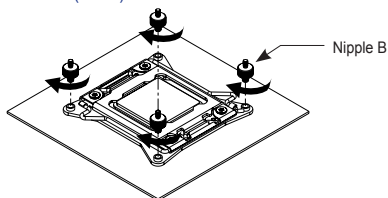

- Install the clip support on the motherboard using nuts.

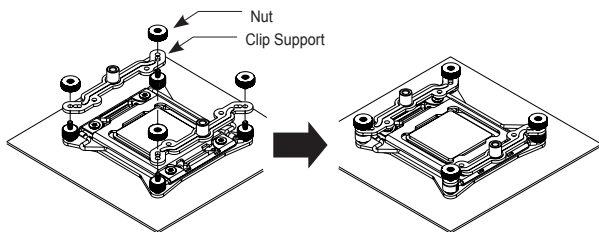

Caution

Please make a note of the orientation of the Clip Support.

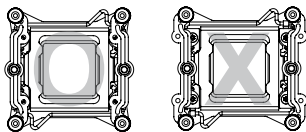

2) Intel Socket 1366 / 1156 / 1155 Installation

- ① Install Bolts to the Backplate according to the Socket Type and secure with Side Caps.

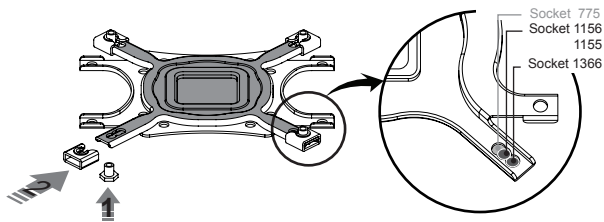

- ② Attach Double-sided Tape to the center of the Backplate and remove the Double-sided Tape's Cover.

※ Socket 1366/1156/1155 Installation does not require the Loading Block.

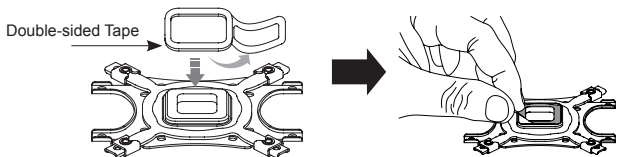

- ③ Align the Backplate's nuts with motherboard's clip support holes, attach it to the back side of the motherboard, and then fix it with Intel's washer and Nipple A.

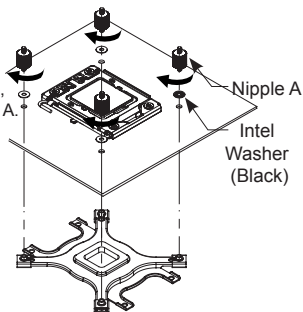

Caution

Please make a note of the orientation of the Clip Support.

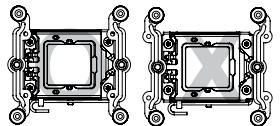

- ④ Install the clip support on the motherboard using nuts.

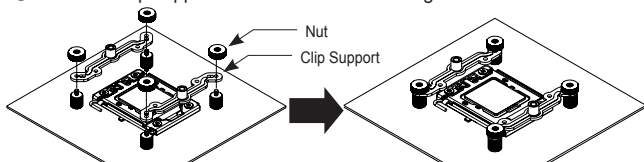

3) Intel Socket 775 Installation

- ① Install Bolts to the Backplate according to the Socket Type and secure with Side Caps.

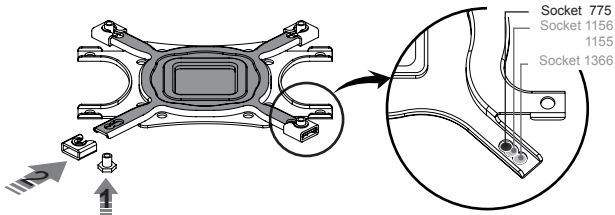

- ② Remove the Sticker Cover from the Lower Tier of the Loading Block and attach it to the Backplate.

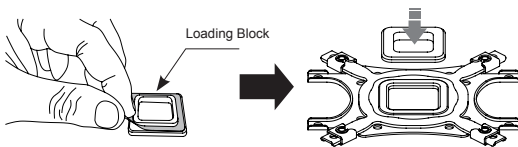

- ③ Attach Double-sided Tape to the Loading Block and remove the Double-sided Tape Cover.

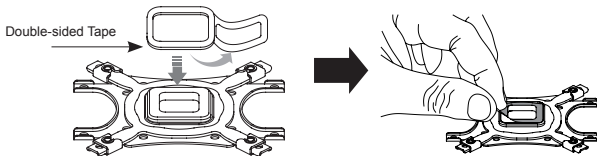

Caution

Please make a note of the orientation of the Loading Block.



- ④ Align the Backplate's nuts with motherboard's clip support holes, attach it to the back side of the motherboard, and then fix it with Intel's washer and Nipple A.

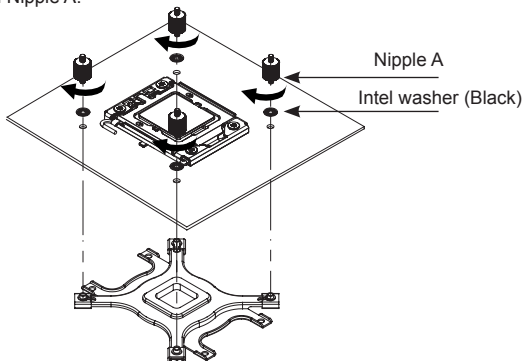

- ⑤ Install the clip support on the motherboard using nuts.

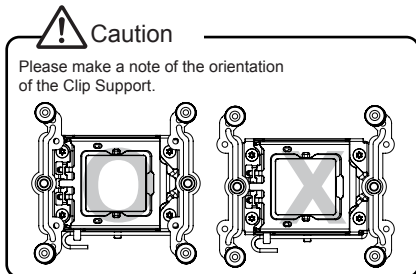
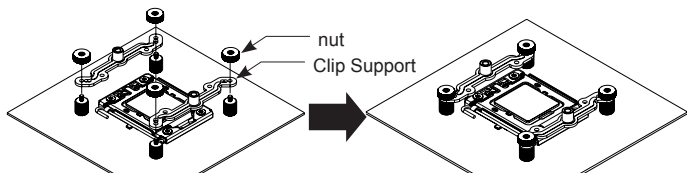

4) AMD Socket FM2 / FM1 / AM3+ / AM3 / AM2+ / AM2 Installation

- ① Install Bolts to the Backplate according to the Socket Type and secure with Side Caps.

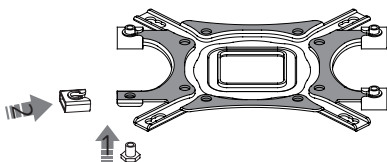

- ② Remove the Sticker Cover from the Lower Tier of the Loading Block and attach to the Backplate.

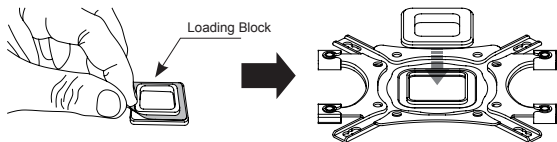

- ③ Attach Double-sided Tape to the Loading Block and remove the Double-sided Tape Cover.

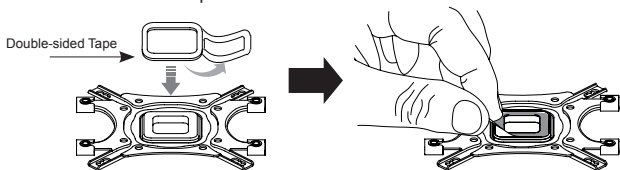

Caution

Please make a note of the orientation of the Loading Block.



- ④ Take away the fixed Clip support from the motherboard, and then install the included Clip support using Nipple A, AMD's transparent washer and nuts.

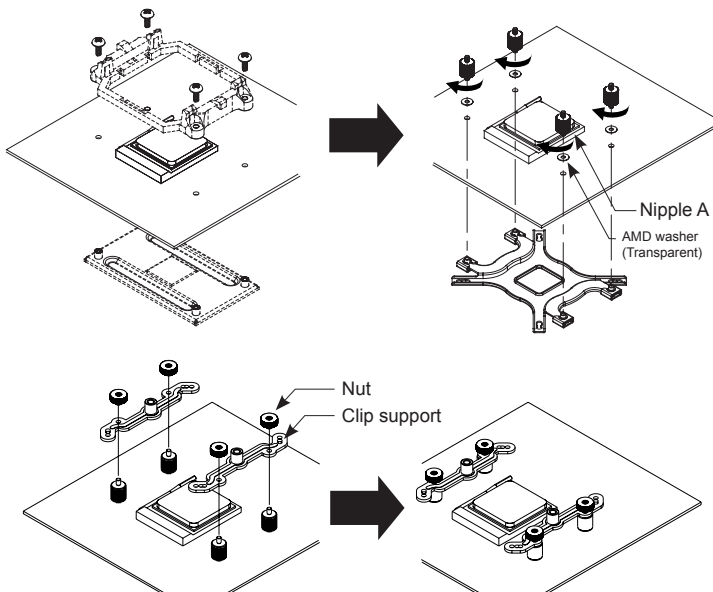

Caution

Please make a note of the orientation of the Clip Support.

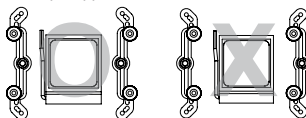

B. Cooler Installation (Intel / AMD Socket)

※ After installation of the Clip Support depending on a user's socket type, install Cooler according to the direction below.

- ① Apply a suitable amount of the included Thermal Grease on the CPU's surface.

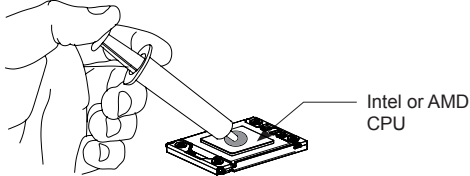

- ② Insert clip into the hole of heatsink's base and fasten bolts by wrench.

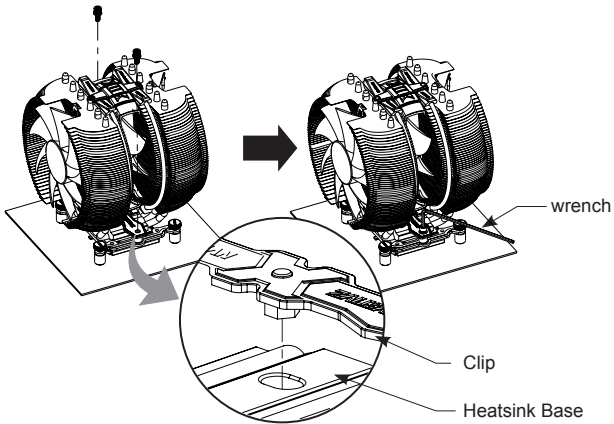

- ③ Connect the cooler's 3-pin connector to the motherboard's CPU Fan header.

